



US00D415719S

United States Patent [19]

[11] Patent Number: Des. 415,719

Sawai et al.

[45] Date of Patent: ** Oct. 26, 1999

[54] **EXTERIOR BODY OF A MOTOR VEHICLE**

[75] Inventors: **Daisuke Sawai; Hideto Kubota; Toshiyuki Fukatsu**, all of Wako, Japan

[73] Assignee: **Honda Giken Kogyo Kabushiki Kaisha**, Tokyo, Japan

[**] Term: **14 Years**

[21] Appl. No.: **29/097,498**

[22] Filed: **Nov. 3, 1998**

[30] **Foreign Application Priority Data**

Jun. 12, 1998 [JP] Japan H10-17063

[51] **LOC (6) Cl.** **12-08**

[52] **U.S. Cl.** **D12/92**

[58] **Field of Search** D12/90-92; 296/185

[56] **References Cited**

U.S. PATENT DOCUMENTS

- D. 284,749 7/1986 Schultz .
- D. 305,998 2/1990 Lagaay .
- D. 338,638 8/1993 Lagaay .
- D. 350,086 8/1994 Kong et al. .
- D. 356,757 3/1995 Lagaay et al. .
- D. 356,982 4/1995 Ramaciotti .
- D. 372,689 8/1996 Sacco et al. .
- D. 380,178 6/1997 Sacco et al. .
- D. 381,295 7/1997 Sawai et al. .
- D. 385,222 10/1997 Hill et al. .
- D. 387,309 12/1997 Syring .
- D. 398,263 9/1998 McGovern D12/92
- D. 405,390 2/1999 Castiglione et al. D12/92

Primary Examiner—Melody N. Brown

Attorney, Agent, or Firm—Nikaido, Marmelstein, Murray & Oram LLP

[57] **CLAIM**

The ornamental design for an exterior body of a motor vehicle, as shown and described.

DESCRIPTION

FIG. 1 is a left-front perspective view of an exterior body of a motor vehicle according to our new design;

FIG. 2 is a right-rear perspective view of an exterior body of a motor vehicle according to our new design;

FIG. 3 is a left side view of an exterior body of a motor vehicle according to our new design;

FIG. 4 is a right side view of an exterior body of a motor vehicle according to our new design;

FIG. 5 is a front view of an exterior body of a motor vehicle according to our new design;

FIG. 6 is a rear view of an exterior body of a motor vehicle according to our new design;

FIG. 7 is a top plan view of an exterior body of a motor vehicle according to our new design;

FIG. 8 is a left-front perspective view of an exterior body of a motor vehicle, with a convertible top lowered, according to our new design;

FIG. 9 is a right-rear perspective view of an exterior body of a motor vehicle, with a convertible top lowered, according to our new design;

FIG. 10 is a left side view of an exterior body of a motor vehicle, with a convertible top lowered, according to our new design;

FIG. 11 is a right side view of an exterior body of a motor vehicle, with a convertible top lowered, according to our new design;

FIG. 12 is a front view of an exterior body of a motor vehicle, with a convertible top lowered, according to our new design;

FIG. 13 is a rear view of an exterior body of a motor vehicle, with a convertible top lowered, according to our new design; and,

FIG. 14 is a top plan view of an exterior body of a motor vehicle, with a convertible top lowered, according to our new design.

The broken lines are for illustrative purposes only and form no part of the claimed design.

1 Claim, 12 Drawing Sheets

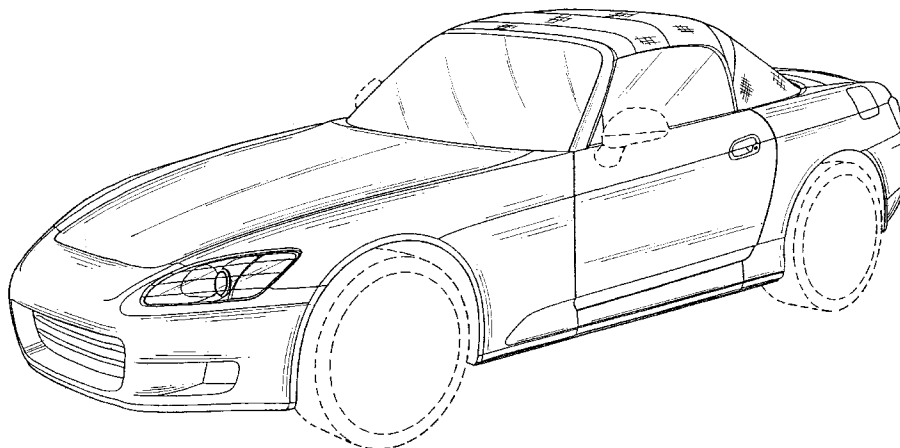

FIG. 1

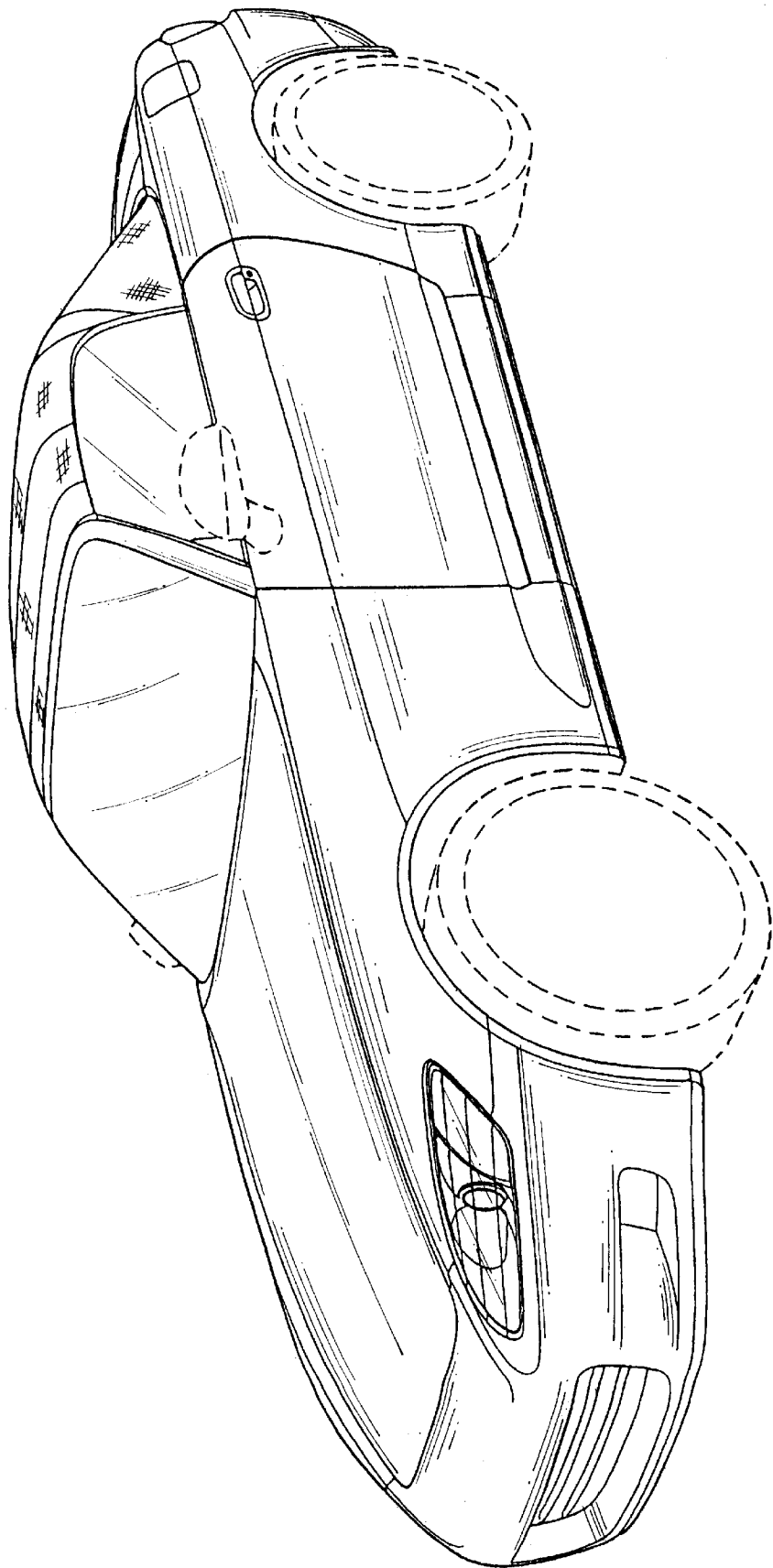

FIG. 2

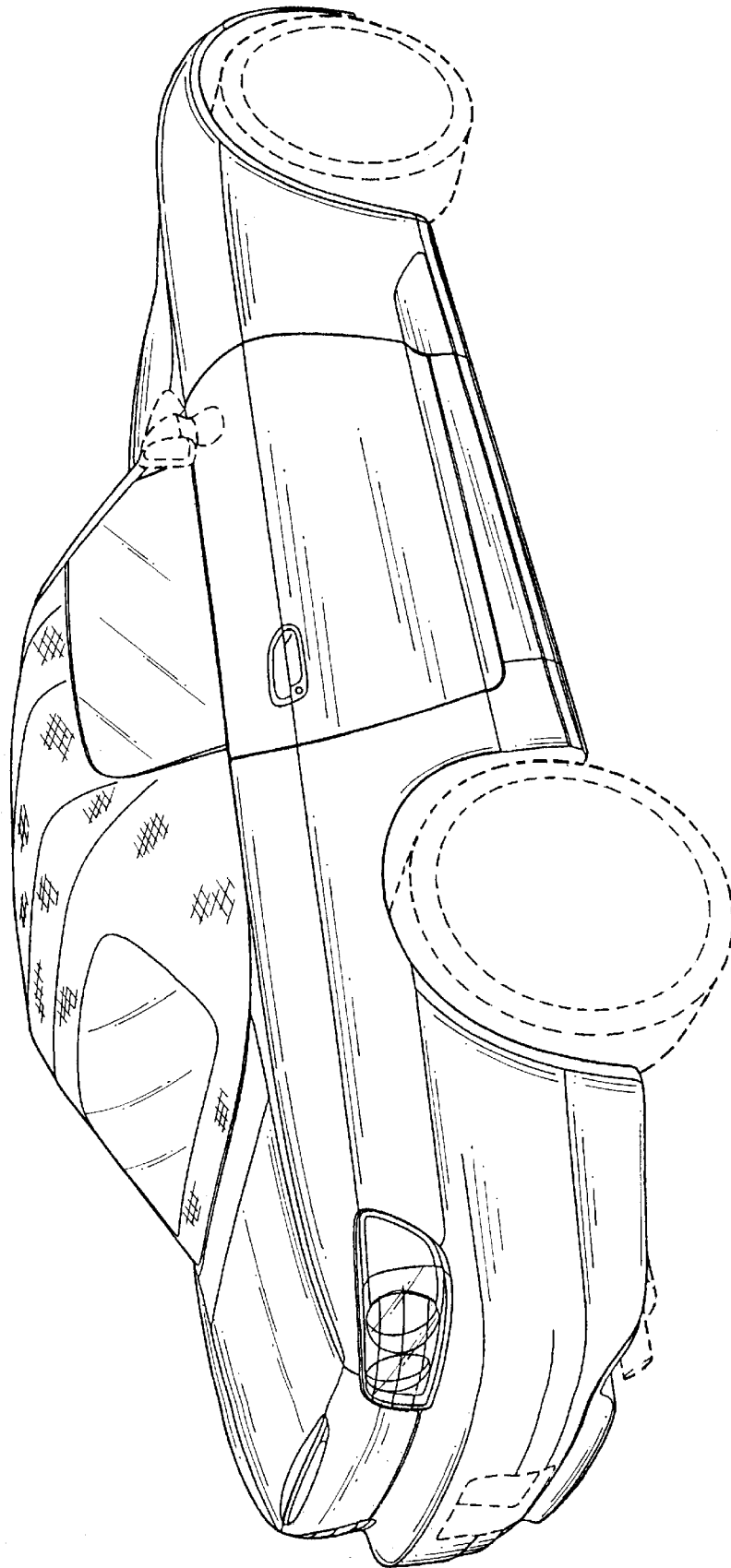

FIG. 3

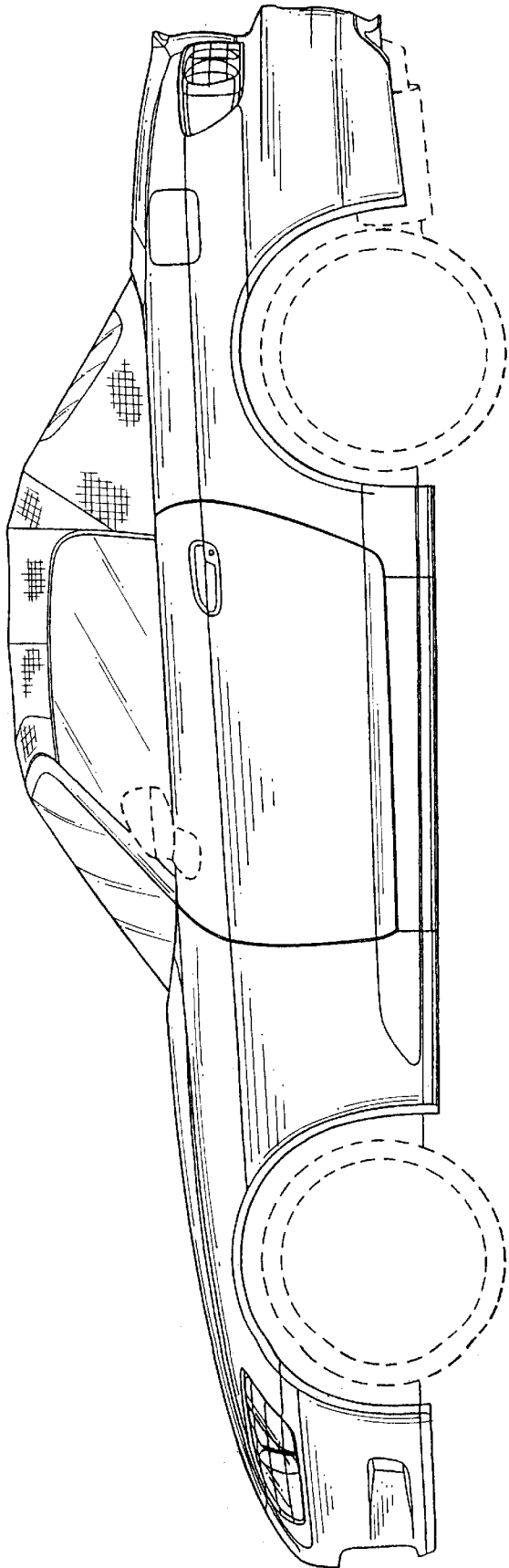

FIG. 4

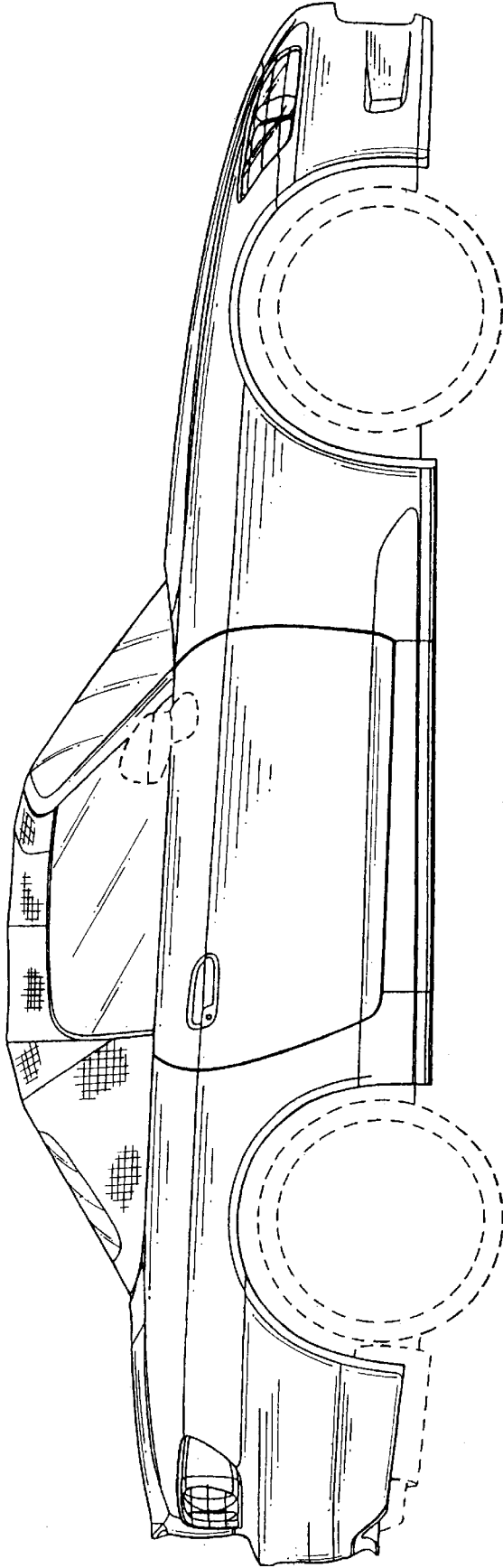

FIG. 6

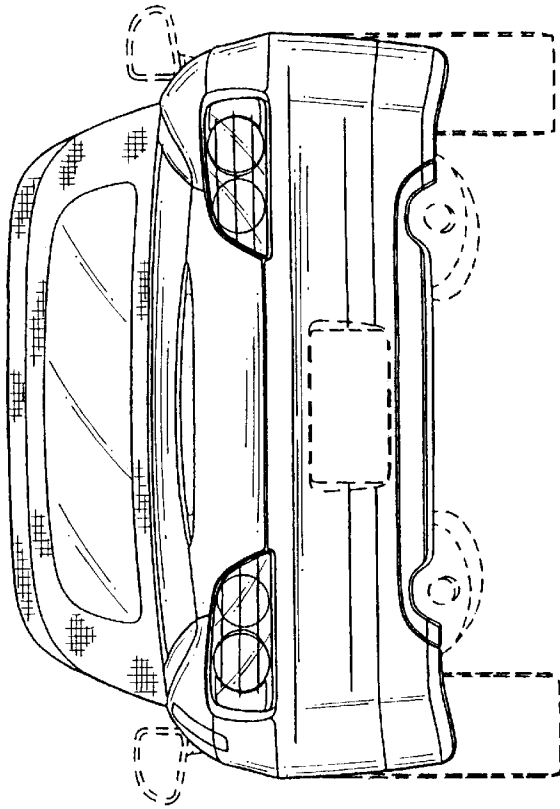

FIG. 5

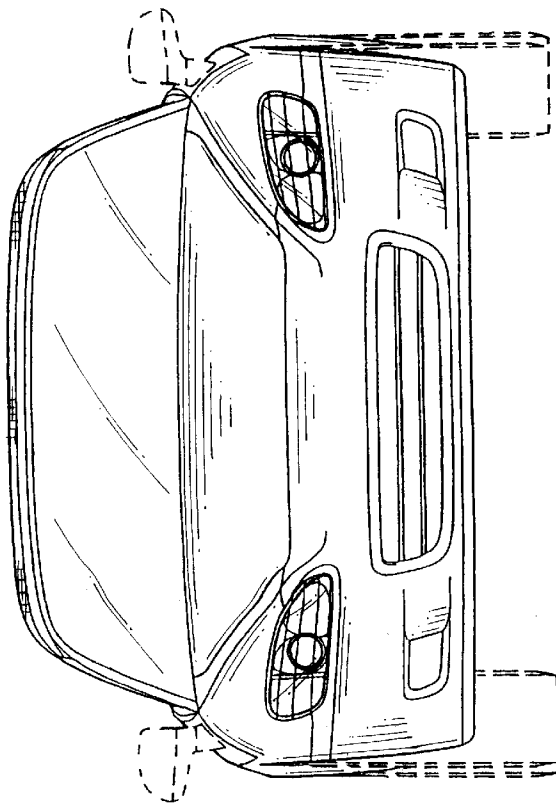

FIG. 7

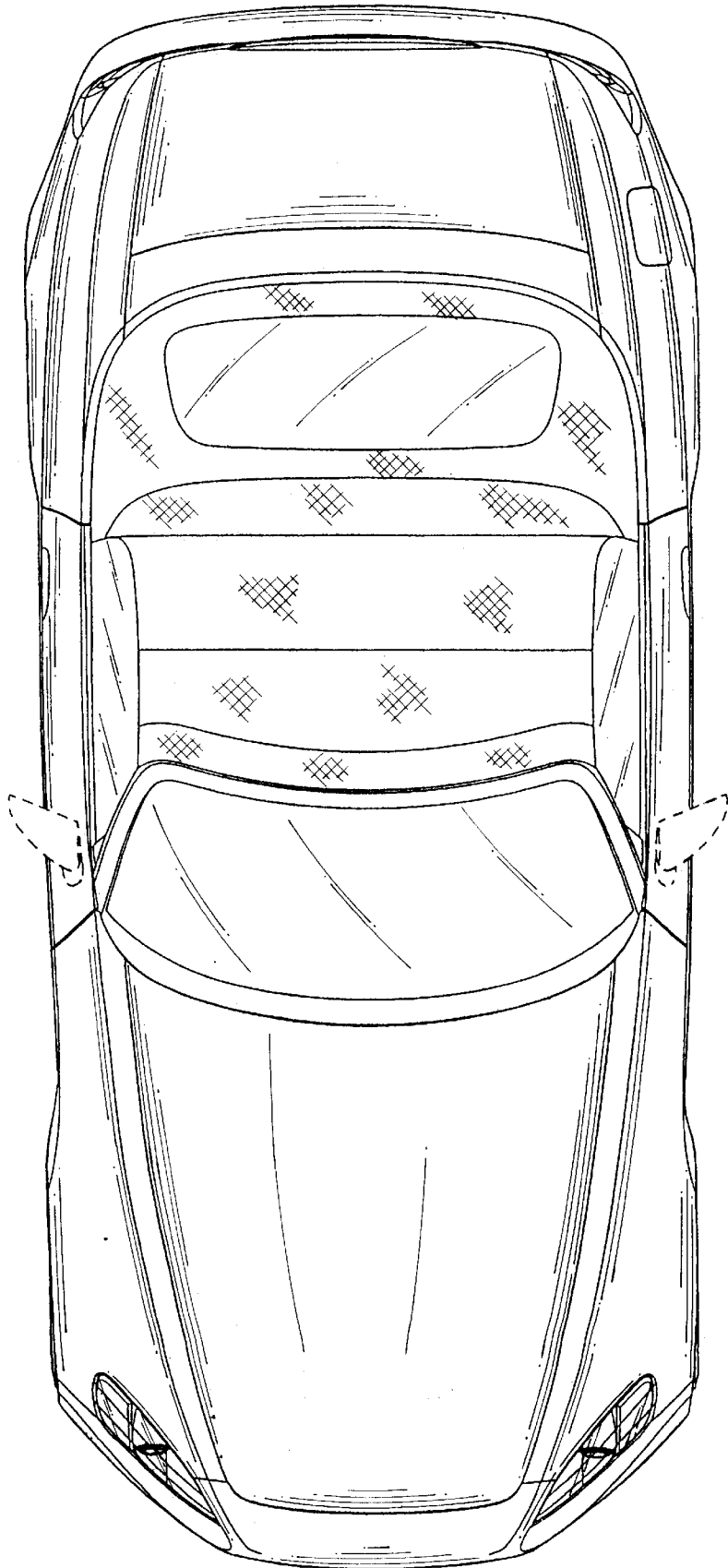

FIG. 8

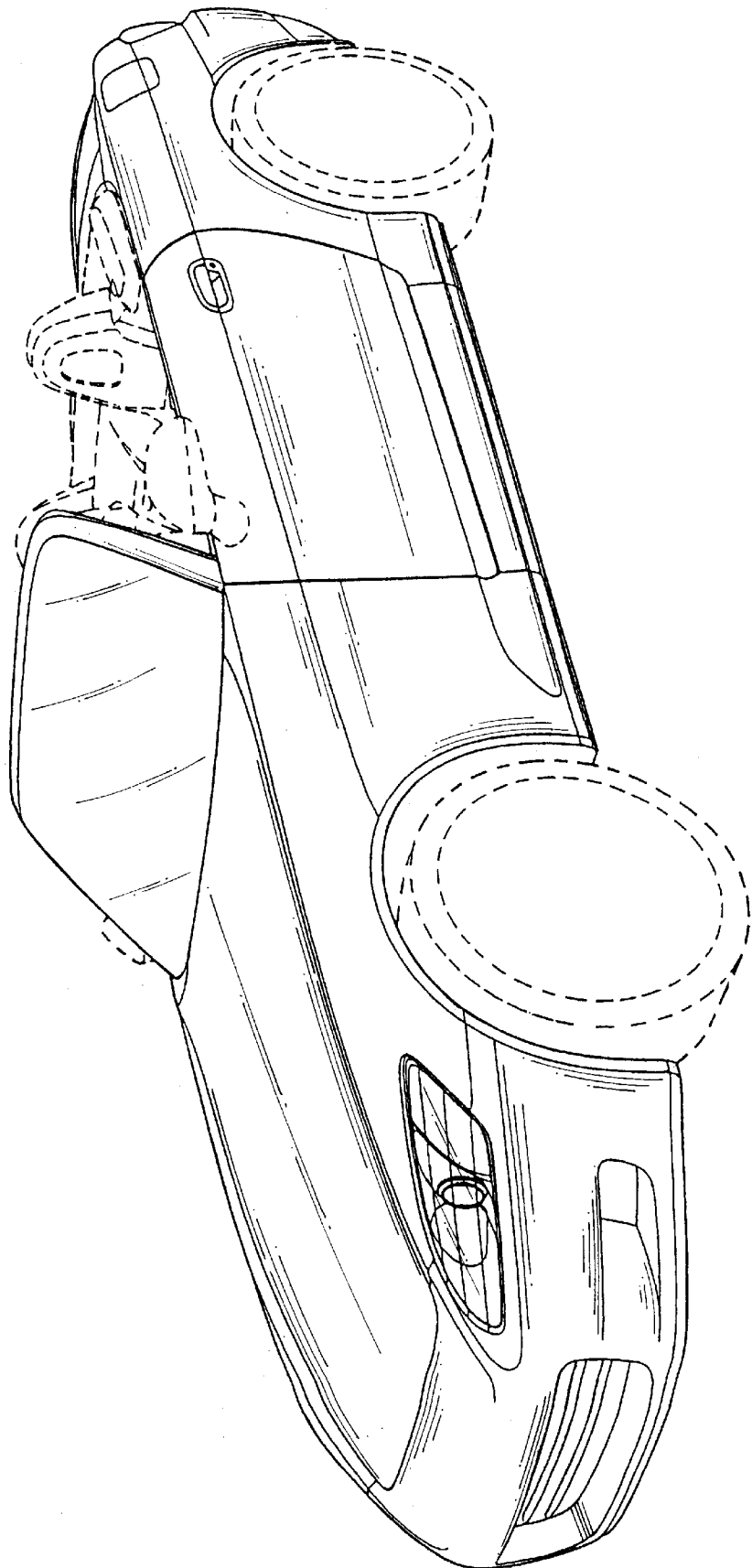

FIG. 9

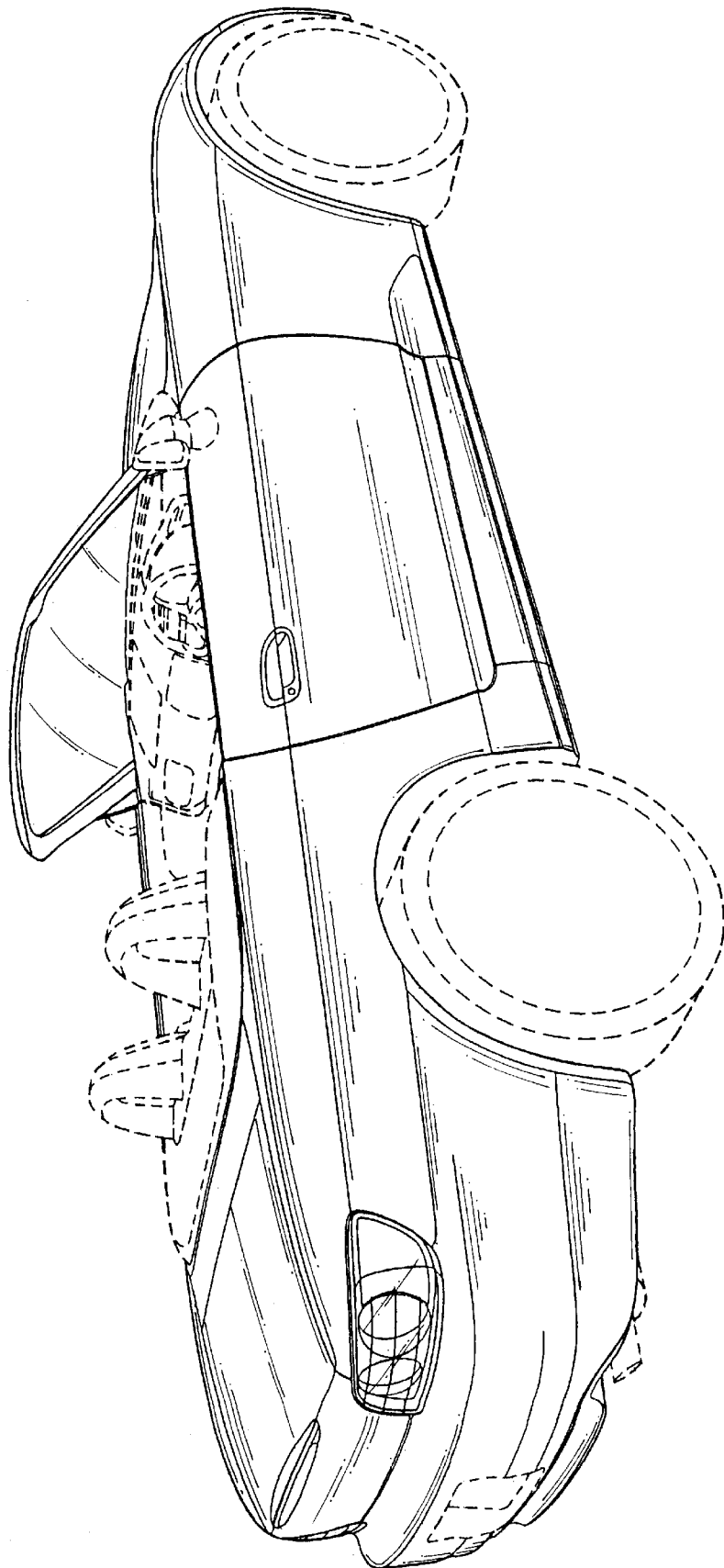

FIG. 10

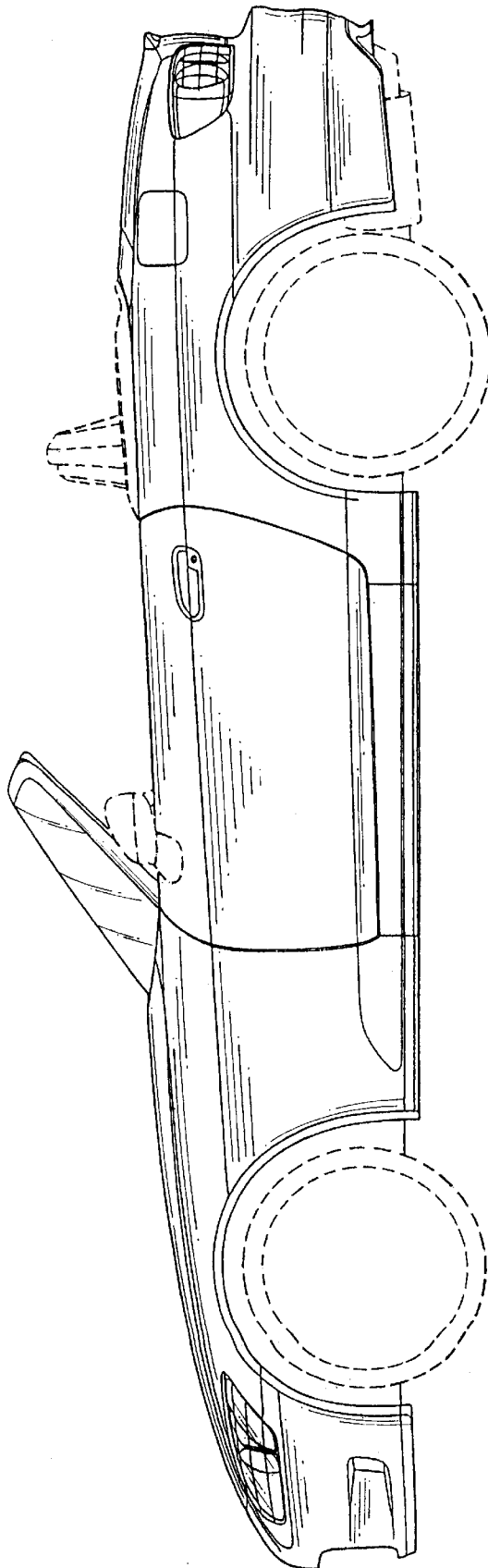

FIG. 11

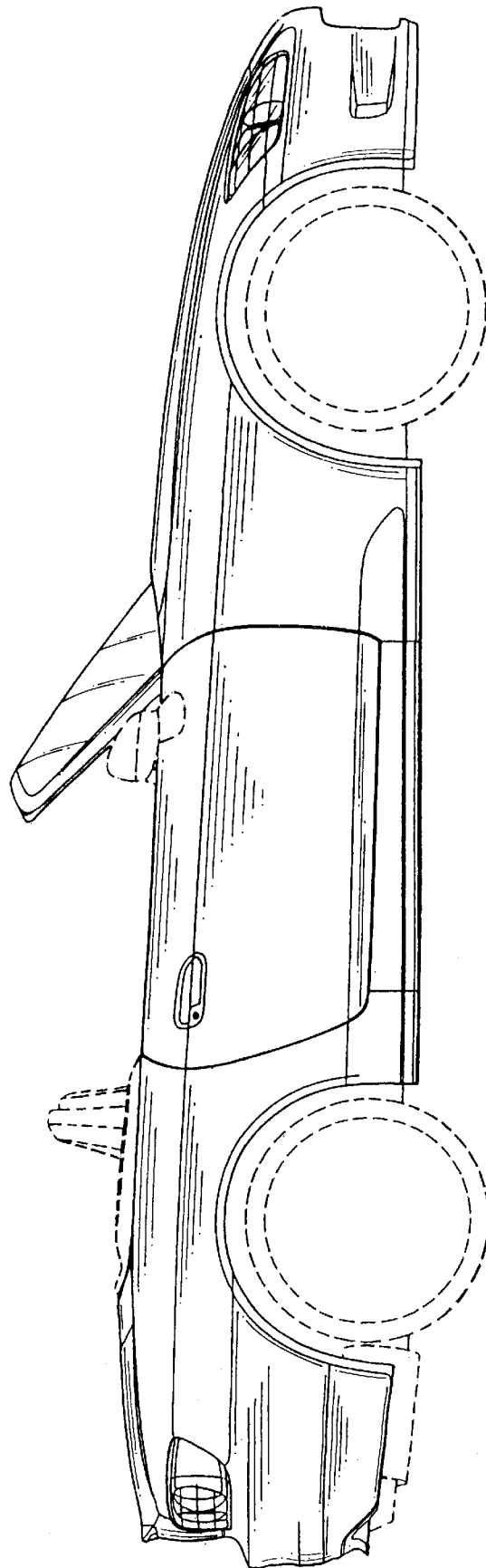

FIG. 13

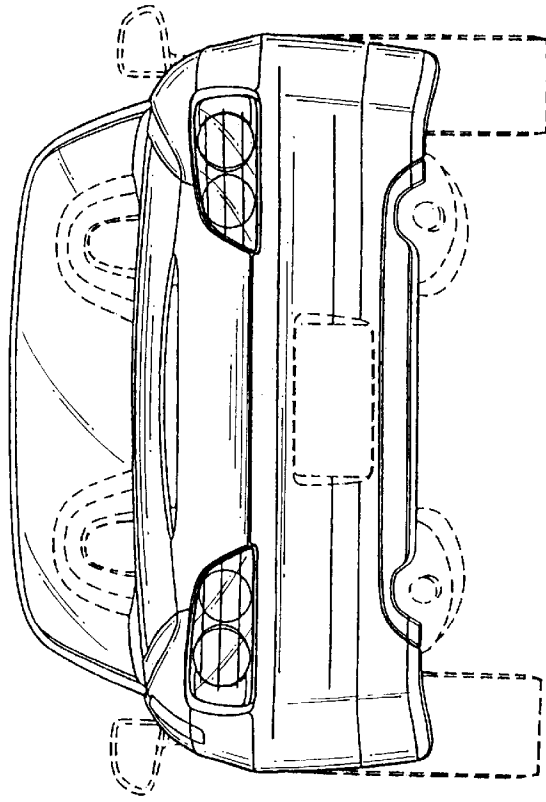

FIG. 12

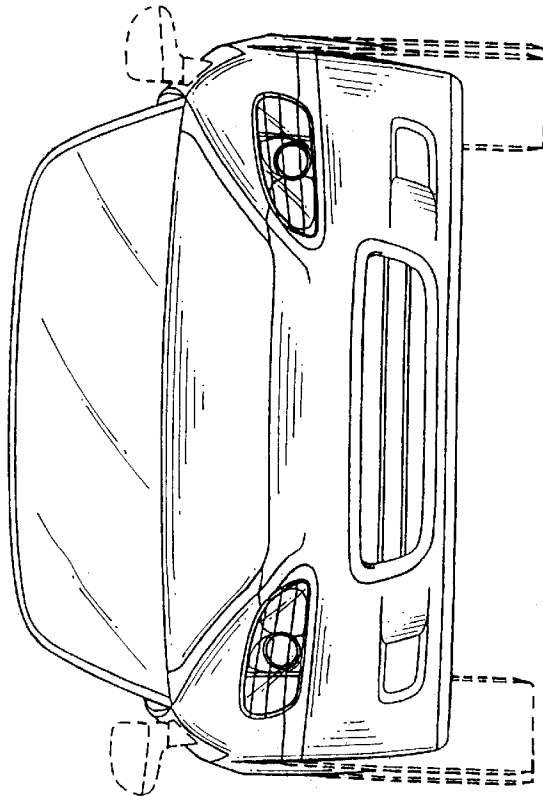

FIG. 14

